

Operator's manual

Caution

This manual
contains important
safety information.

Read manual
carefully.

Keep manual
with Manac's
semitrailer
at all times.

Manac semitrailer



www.manac.us

Operator's instructions

This manual has been prepared to assist you in retaining the safety, dependability, and performance that are built into Manac trailers. It is essential that this semitrailer receives periodic inspections, maintenance, and service parts replacement. This manual includes safety checks that the operator should perform periodically. It is important that every semitrailer owner and/or operator have an organized Semitrailer Preventive Maintenance (TPM) program. United States and Canada Departments of Transportation require by law that the maintenance records be kept on every commercial highway vehicle. It is to your advantage to be able to show that regularly scheduled TPM

inspection checks have been made on every piece of equipment operated.

Not only will a regular TPM program assure you that you will get the most from your Manac semitrailer, but also you may place yourself in a favorable legal position in the event of an accident involving this equipment.

Read this manual carefully. Should you have any questions, contact a Manac Semitrailer factory representative immediately for the answers. This manual should be kept with the semitrailer and should remain with the semitrailer when it is sold.

Table of contents

Operator's instructions	3	Tires	20
Coupling	5	Tire loads	20
Uncoupling	10	Proper use of steps and hand-holds	21
Normal use	12	Rims and wheels	22
Certification plate	13	Spindle axle nut instructions	26
Pre-trip check list	14	Wheels	28
Electrical system	16	Leaf-spring suspension	30-31
Typical wiring diagram	17	Air suspension	32
Slider running gear	18	Suspension safety and inspection	33
Care and adjustment of brakes	19	Exhaust (dump) valve operation	34-35
Air system and brake operation	19	Reporting safety defects	36

Knowing how to couple and uncouple correctly is basic to safe operation of combination vehicles. General coupling and uncoupling steps are listed below. So learn the details of coupling and uncoupling for the truck(s) you will operate.

Coupling Tractor-Semitrailers

Step 1 Inspect Fifth Wheel

- Check for damaged/missing parts.
- Check to see that mounting to tractor is secure, no cracks in frame, etc.
- Be sure that the fifth wheel plate is greased as required. Failure to keep the fifth wheel plate lubricated could cause steering problems because of friction between the tractor and the semitrailer.
- Check if fifth wheel is in proper position for coupling:
 - wheel tilted down towards rear of tractor;
 - jaws opened;

- safety unlocking handle in the automatic lock position;
- If you have a sliding fifth wheel, make sure it is locked.
- Make sure the semitrailer kingpin is not damaged or worn.

Step 2 Inspect Area and Chock Wheels

- Make sure the area around the vehicle is clear.
- Be sure semitrailer parking brakes are applied.
- Check that cargo (if any) is secured against movement caused by the tractor being coupled to the semitrailer.

Step 3

Position Tractor

- Back the tractor directly in front of the semitrailer. (Never back under the semitrailer at an angle, because you might push the semitrailer sideways and damage the support legs.)
- Check position, using outside mirrors, by looking down both sides of the semitrailer.

Step 4

Back Slowly

- Back until fifth wheel just touches the semitrailer.
- Do not hit the semitrailer.

Step 5

Secure Tractor

- Put on the parking brake.
- Put transmission in neutral.

Step 6

Check Semitrailer Coupler Height

- The semitrailer should be low enough so that it is raised slightly by the tractor when the tractor is backed under it. Raise or lower the semitrailer as needed. (If semitrailer is too low, tractor may strike and damage nose of the semitrailer; if semitrailer is too high, **it may not couple correctly**.)
- Check that the kingpin and fifth wheel are aligned.

Coupling Height Caution

It is important to verify before coupling your Manac semitrailer if fifth wheel coupling height is compatible with the semitrailer coupling height. Too high or too low fifth wheel coupling height may result in premature weariness, tires, brakes, bearings etc. Also too high coupling height may result to an overall dimension higher than 13'6".

SAMPLE

**CAUTION
13'6" HIGH**

**MAXIMUM
FIFTH WHEEL
HEIGHT
47"**

Step 7 Connect Air Lines to Semitrailer

- Check glad hand seals and connect tractor supply (emergency) air line to semitrailer supply (emergency) glad hand.
- Check glad hand seals and connect tractor control (service) air line to semitrailer control (service) glad hand.
- Make sure air lines are safely supported where they will not be crushed or caught while tractor is backing under the semitrailer.

Step 8 Supply Air to Semitrailer

- From the cab, push in “Air Supply” knob or move tractor protection control valve from the “Emergency” to the “Normal” position to supply air to the semitrailer brake system.
- Wait until the air pressure is normal.
- Check brake system for crossed air lines:
 - shut engine off so you can hear leaks in the brake system;

- apply and release semitrailer brakes. Listen for sound of semitrailer brakes being applied and released. You should hear the brakes move when applied and air escape when the brakes are released;
- check air brake system pressure gauge for signs of major air loss;
- When you are sure semitrailer brakes are working, start engine.
- Make sure air pressure is up to normal.

Step 9 Lock Semitrailer Brakes

- Pull out the “Air Supply” knob or move the tractor protection control valve from “Normal” to “Emergency”.

Step 10 Back Under Semitrailer

- Use lowest reverse gear.
- Back tractor slowly under semitrailer to avoid hitting the kingpin too hard.
- Stop when the kingpin is locked into the fifth wheel.

Step 11

Check Connection for Security

- Raise semitrailer support legs slightly off ground.
- Pull tractor gently forward while the semitrailer brakes are still applied.

Step 12

Secure Vehicle

- Put transmission in neutral.
- Put parking brakes on.
- Shut off engine and take the key with you so someone else will not move the tractor-semitrailer while you are under it.

Step 13

Inspect Coupling

- Use a flashlight if necessary.
- Make sure there is no space between upper coupler and fifth wheel. If there is space, something is wrong (kingpin may be on top of closed fifth wheel jaws; semitrailer could come loose very easily).
- Go under semitrailer and look into the back of the fifth wheel. Make sure the fifth wheel jaws have closed around the shank of the kingpin.

- Check that the locking lever is in “lock” position.
- Check that the safety catch is in position over locking lever. (On some fifth wheels, the catch must be put in place by hand.)
- If the coupling is not right, do not drive the coupled unit; get it fixed.

Step 14

Connect the Electrical Cord and Check Air lines

- Plug the electrical cord into the semitrailer and fasten the safety catch.
- Check both air lines and electrical line for signs of damage. Repair or replace if necessary.
- Make sure air and electrical lines will not hit any moving parts of vehicle.

Caution

Connector wiring change

Notice for all tractor-semitrailer owners and users

Federal Motor Vehicle Safety Standard No. 121, Air Brake Systems, was amended by the National Highway Traffic Safety Administration of DOT requiring that truck tractors manufactured on/or after March 1, 1997, provide constant power for a semitrailer's antilock brake system (ABS). Some manufacturers will provide this feature prior to the effective date. These tractors using a single 7-way electrical connector will have constant power for ABS on the center pin when the key switch is on. Tractor-semitrailer owners and users who presently use the center pin for auxiliary power for equipment other than semitrailer ABS (for example: dome lights, backing lights, bottom dumps, sliding undercarriages, air ride dump valves, etc.) will be affected by this change. In certain uses of this constantly powered center pin connector, unexpected or unintended activation of this equipment may be hazardous or result in personal injury. Before connecting your semitrailer to a tractor, make sure that the constantly powered center pin will not unintentionally turn on semitrailer equipment. If you have any questions about your present wiring, or how to rewire your vehicles, you should contact the tractor supplier and/or MANAC Customer Service Department.

Step 15

Raise Semitrailer Support Legs (Landing Gear)

- Use low-gear range (if so equipped) to begin raising the support legs. Once free of weight, switch to the high-gear range.
- Raise the support legs all the way up. (Never drive with support legs only part way up as they may catch on railroad tracks or other things.)
- After raising the support legs, properly secure the crank handle.
- With the front of the semitrailer supported by the tractor:
 - check for enough clearance between rear of tractor frame and support legs. (When tractor turns sharply, it must not hit the support legs or their bracing);
 - check that there is adequate clearance between the top of the tractor tires and the underside of the semitrailer.

Uncoupling

Uncoupling Tractor-Semitrailers

The following steps will help you to uncouple safely.

Step 1 Position Rig

- Make sure surface of parking area can support weight of semitrailer.
- Place tractor in a straight line with the semitrailer. (Pulling out at an angle can damage the support legs.)

Step 2 Ease Pressure on Locking Jaws

- Shut off semitrailer air supply to lock semitrailer brakes.
- Ease pressure on fifth wheel locking jaws by backing up gently (this will help you release the fifth wheel locking lever).
- Put parking brakes on while tractor is pushing against the kingpin. This will hold rig with pressure off the locking jaws.

Step 3 Lower The Support Legs

- Lower the support legs until they make firm contact with the ground. Turn crank in low gear a few extra turns. This will lift some weight off the tractor. (Do not lift semitrailer off the fifth wheel.) This will:
 - make it easier to unlatch fifth wheel;
 - make it easier to couple next time.

Step 4 Disconnect Air Lines and Electrical Cable

- Disconnect air lines from semitrailer. Connect air line glad hands to dummy couplers at back of cab, or couple them together.
- Hang electrical cable with plug down to prevent moisture from entering it.
- Make sure lines are supported so they will not be damaged while driving the tractor.

Step 5**Unlock Fifth Wheel**

- Raise release handle lock.
- Pull the release handle to “open” position.
- Keep legs and feet clear of the rear tractor wheels to avoid serious injury in case the vehicle moves.

Step 6**Pull Tractor Partially Clear of Semitrailer**

- Pull tractor forward until fifth wheel comes out from under the semitrailer.
- Stop with tractor frame under semitrailer (prevents semitrailer from falling to ground, if support legs should collapse or sink).

Step 7**Secure Tractor**

- Apply parking brakes.
- Place transmission in neutral.

Step 8**Inspect Semitrailer Support**

- Make sure ground is supporting semitrailer.
- Make sure support legs are not damaged.

Step 9**Pull Tractor Clear of Semitrailer**

- Release parking brakes.
- Check and drive tractor clear.

Normal use

This Manac semitrailer was designed for operation within legal highway speed limits on reasonable road surfaces for the type of service it was built to perform in accordance with the following:

1. this semitrailer was built to carry cargo within the limitations of weight ratings shown on the certification/identification plate. These ratings, GAWR and GVWR are:
 - a. the GAWR (gross axle weight rating) is the structural capability of the lowest rated member of the running gear components: suspension and spring system, hub, wheels and drums, rims, bearings, brakes, axles or tires.
 - b. the GVWR (gross vehicle weight rating) is the structural capability of the semitrailer when supported by the kingpin and axles with the load uniformly distributed throughout the cargo space.
 - c. this semitrailer will carry a total payload of the Gross Vehicle Weight Rating (GVWR) less the weight of the semitrailer.
2. the cargo should be properly loaded, blocked, and braced to prevent load shifts and to comply with the existing regulations of the North American Cargo Securement Harmonisation.

Caution

The maximum load indicated on the certification/identification plate may or may not be a legal load on the highway you plan to use.

Certification plate

MANUFACTURED BY:
FABRIQUÉ PAR:
MANAC TRAILERS USA INC.
AU/IN USA



DATE: 08/2011

GVWR LB
PNBV

KG

MODEL

AXLES ESSIEUX	GAWR PNBE		TIRES PNEUS	RIMS JANTES	COLD INFL. PRESSURE PRESS. GONFL. À FROID		DUAL JUMELÉS	SINGLE SIMPLE
	LB	KG			PSI	KPA		
FRONT	21000	9525	11R24 5 (G)	24.5X8.25	100	689	X	
REAR	21000	9525	11R24 5 (G)	24.5X8.25	100	689	X	

V.I.N.

5MC314226CP013847

TYPE **TRA/REM**

THIS VEHICLE CONFORMS TO ALL APPLICABLE US FEDERAL MOTOR VEHICLE SAFETY STANDARDS IN EFFECT ON THE DATE OF MANUFACTURE SHOWN ABOVE.

"THIS VEHICLE CONFORMS TO ALL APPLICABLE STANDARDS PRESCRIBED UNDER THE CANADIAN MOTOR VEHICLE SAFETY REGULATIONS IN AFFECT ON THE DATE OF MANUFACTURE/ CE VÉHICULE EST CONFORME À TOUTES LES NORMES QUI LUI SONT APPLICABLES EN VERTU DU RÉGLEMENT SUR LA SÉCURITÉ DES VÉHICULES AUTOMOBILES DU CANADA EN VIGUEUR À LA DATE DE SA FABRICATION"

Pre-trip check list

BUREAU OF MOTOR CARRIER SAFETY
WASHINGTON, D.C.

Open letter to all Truck Drivers

The brochure has been prepared as part of our continuing effort to improve the safety of operation on the highway of commercial motor vehicles. We fully recognize that you, as a professional truck driver, play a key part in our mutual effort to reduce deaths, injuries, and property damage accidents involving trucks.

In order to assist you in doing a better job, we have prepared a pre-trip check list designed to provide a safe, sequential, and timesaving procedure to check your truck - thus helping to assure you a safe trip. This list includes the Federal regulatory pretrip check requirements. However, and more importantly, it is intended to provide you, the professional driver, with a reminder to do what you should always do - check your equipment before each trip.

The recommended procedure can be likened to a pilot performing his preflight check on the aircraft before takeoff. Much of the preflight check is a visual inspection, and the same type procedure can be equally effective in a truck precheck.

Remember - you, the driver, are in the best position to know your truck - you are truly the first line of defense against unsafe vehicles.

Sincerely yours,

Director of Motor Carrier Safety

INSIDE

Parking brake (apply)

START ENGINE

Oil pressure
(light or gauge)

Air pressure (gauge)

Low air warning
device:

- air pressure below 40 psi, check on pressure build-up.
- air pressure above 60 psi, deplete air until warning device works.

Instrument panel
(telltale lights or buzzers)

Horn

Windshield wiper
and washer

Heater-defroster

Mirrors

Steering wheel
(excessive play)

Apply semitrailer
brakes
in emergency

Turn on all lights,
including 4-way
flasher

Fire extinguisher and
warning devices.

OUTSIDE

FRONT

- Headlights
- Clearance lights
- Identification lights
- Turn signals and 4-way flasher
- Tires and wheels (lugs)

LEFT SIDE

- Fuel tank and cap
- Sidemarker lights
- Reflectors
- Tires and wheels (lugs)
- Cargo tie-downs or doors

REAR

- Tail lights
- Stop lights
- Turn signals and 4-way flasher
- Clearance lights
- Identification lights
- Reflectors
- Tires and wheels (lugs)
- Rear end protections (bumper)
- Cargo tie-downs or doors

RIGHT SIDE

- Fuel tank and cap
- Sidemarker light
- Reflectors
- Tires and wheels (lugs)
- Cargo tie-downs or doors

ON COMBINATIONS

- Hoses and couplers
- Electrical connector
- Couplings (fifth wheel, tow bar, safety chains, locking devices)

ON VEHICLES

TRANSPORTING

HAZARDOUS MATERIALS

- Marking or placards
- Proper shipping papers

INSIDE

STOP ENGINE

- Release semitrailer emergency brakes
- Apply service brakes -air loss should not exceed:
 - 1 psi per minute on single vehicles;
 - 2 psi per minute on combinations.

FASTEN SEAT BELTS BEFORE DEPARTURE

Warning

Most pre-trip inspections are visual. Check electrical wiring, brake hoses and other brake components, distorted or broken structural components and welds. Report all defects to the proper persons before deciding to start your trip.

Caution See “Connector wiring change” page 9.

The lights and wiring system on a Manac semitrailer meet or exceed all federal and state requirements in effect at the time of manufacture. Wherever required by law, lights and reflectors are marked by the manufacturer to indicate the appropriate specification with which each complies.



For optimum performance and long life from the semitrailer's lights and wiring, follow this inspection procedure:

- Clean all reflectors and lights. See that all lights burn properly. Replace all burned out lights and broken reflectors. Factory approved replacement parts should be used, and replacement bulbs of equal candlepower should be used for safety.

- Inspect all wiring to see that it is not frayed and that it is properly supported and protected, with all connections tight. See that the light cable is clear and long enough to permit jack-knife parking. Be certain that the cable is supported so that it cannot be pinched or entangled by the lower and upper couplers. Keep the 7-way plug on the light cable and the 7-way connector on the semitrailer, free of corrosion.

- Never replace fuses or breakers with metal foil or other devices.

Usual electrical front plug configurations used by ManacV

CONNECTEUR SAE J560 CONNECTOR 		GRD RETURN TO TOWING VEH. (1) CLR, S.M. AND ID LAMPS (2) LEFT TURN SIG. + HAZARD (3) STOP LAMPS + ANTILOCK (ABS) (4) RIGHT TURN SIG. + HAZARD (5) TAIL + LICENCE PLATE LAMPS (6) ABS CONTINUOUS SHARED POWER + STEERABLE AUTO-LIFT CONTROL + DOME LAMPS (7)	(1) WHT / BLANC (2) BLK / NOIR (3) YEL / JAUNE (4) RED / ROUGE (5) GRN / VERT (6) BRN / BRUN (7) BLU / BLEU	(1) MISE À LA MASSE (2) G. GABARIT, POSITION & IDENTIFICA. (3) CLIGNOTANT GAUCHE + F. URGENCE (4) F. FREINAGE + FREINS ABS (5) CLIGNOTANT DROIT + F. URGENCE (6) F. ARRIÈRE + LAMPE PL. D'IMMATRI. (7) ALIMENTATION CONTINU DE L'ABS + CONTRÔLE DE L'AUTO-VEUR + LAMPES DE TOIT
CONNECTEUR ISO 3731 CONNECTOR 		GRD RETURN TO TOWING VEH. (1) DOOR LOCK + DROP VALVE (2) ABS MALFUNCTION SIGNAL (3) AIR LIFT (4) 2nd AIR-LIFT + BLOW DOWN (5) BACK-UP LAMPS (6) NOT USE (7)	(1) WHT / BLANC (2) BLK / NOIR (3) YEL / JAUNE (4) RED / ROUGE (5) GRN / VERT (6) BRN / BRUN (7) BLU / BLEU	(1) MISE À LA MASSE (2) BARRURE PORTE + VALVE DE PURGE (3) SIGNAL D'ERREUR SYSTÈME ABS (4) SUSPENSION LEVANTE (5) 2e SUSP. LEVANTE + VIDAGE D'AIR (6) LAMPES DE REcul (7) NON UTILISÉE

(REV. 02/2005) 303-8048

Typical wiring diagram

Notice

If the ABS indicator lamp comes on and stays on when you apply the brakes to a moving vehicle, the trailer ABS is not working properly. The ABS must be serviced as soon as possible upon completion of your trip to ensure full anti-lock braking capability.

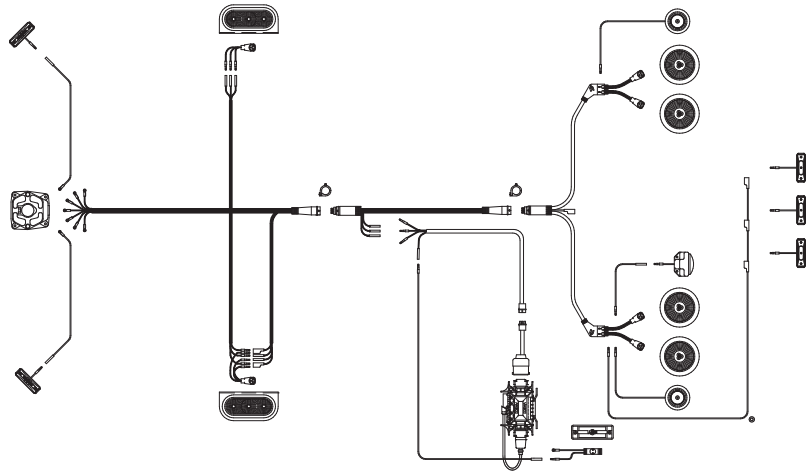

Slider running gear

Reposition the slider

1. Set the tractor and semitrailer brakes.
2. Remove the stop bar and move to desired position.
(Picture A)
3. Determine whether the slider has on air assisted or a manual pin release system. (Picture B)
4. Air assisted: disconnect the safety glad hand. Connect the truck tractor safety glad hand to the third auxiliary glad hand. Pins will disengage. (See decal on front)
5. Manual pins: release the operating handle for mechanical pin release. (See decal on semitrailer side)
6. Gently rock the semitrailer forward and rearward to fully retract the pins.
7. Slide the slider to the desired position by ONLY releasing the tractor brakes and carefully moving the semitrailer until the slider contacts the stop bar.
8. Release the operating handle.
9. Visually check all locking pins for proper engagement. Chamfered ends of the pins must project through the body rail at all four locations. (Picture C)
10. Locate the stop bar directly behind the slider system.
(Picture D)
11. Check pin engagement by gently rocking the semitrailer forward and rearward.

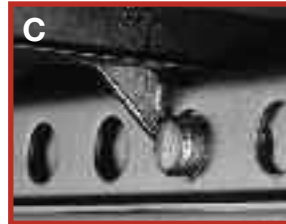

Caution

Failure to properly secure slider box to body rail can cause loss of vehicle control that can result in death or serious injury and property damage.

Care and adjustment of brakes

The semitrailer brake systems will perform safely and efficiently only as long as you maintain them properly and do not abuse them. Semitrailer brakes should be inspected frequently and adjusted, if needed, in connection with a Semitrailer Preventive Maintenance program.

Out-of-adjustment brakes can cause increased stopping distance, shorter brake component life, and a tendency for the semitrailer, and the truck tractor equipment to jack-knife.

Air system and brake operation

- Inspect the glad hands for seal damage and cracked housings. Inspect the air hoses for cracking and for frayed connections. Replace or repair damaged components.
- Keep the air system clean. Air tanks should be drained daily to remove moisture and other contaminants, especially during cold weather operations.
- Use of additives as antifreeze in the air brake system is not recommended. They may result in deterioration of valve seals and effect performance of the brake system.
- Keep the air system tight. The air system cannot be charged properly if there are leaks in reservoirs, lines, hoses or valves.
- Run the tractor engine until the air brake system pressure gauge shows at least 105 psi. With the engine off, listen for air leaks and check the gauge reading with no brakes applied. Remember that serious air losses are extremely hazardous conditions that might cause accidents or breakdowns.

Caution

Do not operate this vehicle with any brake defects or with brakes not well adjusted.

Tires

Do not over inflate. Check for proper inflation with an accurate gauge when the tires are cold. Check the spare too. Inspect tires for nails and other objects embedded in the rubber, and for stones and other objects lodged between duals.

Examine tires to see that they are free of breaks and other defects. Examine new and retread tires for signs of failure during the break in period. Dual tires on any axle end should have the same diameter.

Tire loads

The total load per tire must not exceed the tire manufacturer's specified load carrying capacity at stated inflation pressures for tires and rims. For your information, Manac has assigned Gross Axle Weight Ratings (GAWR) for each semitrailer. (See "Certification plate" page 13.)

The GAWR and tire information shown on the vehicle certification plate was applicable at the time the semitrailer was manufactured. If the tires or other components of the running gear have been changed or altered since the semitrailer was manufactured, the GAWR may have changed.

Proper use of steps and hand-holds

Proper use of steps and hand-holds

Use all steps and hand-holds with extreme caution. Such components are subject to wear, damage and environmental conditions. Make sure these components are firmly attached and properly maintained. If you suspect that they are not, do not use them. If steps are wet, iced or for some reason seem to be slippery, they must not be used.

Climbing Practices

1. Face inward (toward the semitrailer) at all times while climbing up and going down.
2. Maintain a three-point contact at all times.
3. Wear slip-resistant footwear.

Warning

1. Do not climb steps which are not firmly attached and properly maintained.
2. Do not climb or go down steps with any item in your hands.
3. Do not use a tractor not equipped with a safe, adequate climbing system to access the semitrailer's front wall steps.
4. Do not step on tires, fenders, tractor frames, or mudflap supports.
5. Do not step over air and electrical lines between the tractor and the semitrailer. Disconnect and properly store if necessary.
6. Do not use an access system if wet, iced, or for any reason seems to be slippery.
7. Do not use a semitrailer front wall access system to start, inspect, or maintain any heating or cooling unit.
8. Do not climb higher than necessary to open, secure or close the vent door.
9. Do not remain on a semitrailer access system while it is being coupled to or uncoupled from a tractor.
10. Do not jump from the semitrailer to the ground.

Rims and wheels

Check all parts for damage, including wheels and ring clamp. Insure that studs, nuts and mounting faces of hub and wheels are clean and free from grease. Replace any defective part.

Mount single wheel or inner dual wheel (also, outer dual wheel for hubtype mounting) over studs, being careful not to damage stud threads. Draw up nuts alternately into the sequence shown at right. Do not tighten them fully, however. This procedure will permit the uniform seating of nuts and ensure the even face-to-face contact of wheels and hub.

Tighten nuts fully, using the same alternate sequence. Mount the outer wheel (for double cap mounting) and repeat the entire procedure. In each case, be sure to tighten wheel nuts only to the torque level recommended in the table below and to maintain them at that level through planned, periodic checks.

Note

Rim nuts should be rechecked for proper torque after vehicle has been operated for 50-100 miles, and every 2,000 to 10,000 miles thereafter, as well as during regular maintenance checks. Do not intermix wheel types. Insufficient mounting torque can cause wheel shimmy, resulting in damage to parts and extreme tire tread wear and that can result in death or serious injury. Excessive mounting torque can cause studs to break and discs to crack in the stud hole area.

Nut tightening recommended practice for wheel/rims installation

Nut tightening sequence.

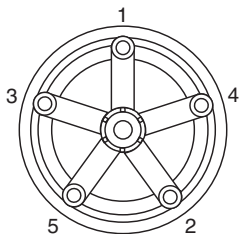

5 SPOKES

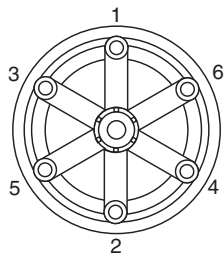

6 SPOKES

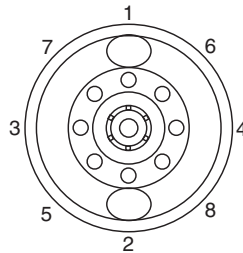

8 STUDS

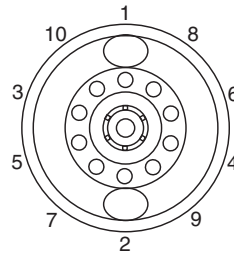

10 STUDS

Caution

After the first 50 to 100 miles of operation, retighten again to avoid rim slippage, wheel damage or loss of rims.

RECOMMENDED TORQUE

DRY THREADS	ft-lb
SPOKE WHEELS	200-260
DISC WHEELS	450-500

Check torque every 10,000 miles (max.)

Rim and wheel maintenance during tire inspections

1. Check all metal surfaces thoroughly while making tire inspections, including areas between duals and on inboard side of wheel. Watch for:
 - a. excessive rust or corrosion build-up
 - b. cracks in metal
 - c. bent flanges, resulting from road obstructions
 - d. deep rim tool marks on rings or in gutter areas
 - e. loose, missing or damaged nuts or clamps
 - f. bent or stripped studs
 - g. damaged or missing rim drive plates
 - h. matched rim parts
2. Pull damaged rims or wheels.
3. Mark damaged or hazardous areas so that the part will be removed from service.
4. Replace damaged parts. Ensure that replacements are made with the proper sizes and types of rims and rings.
5. Inflate tires only to recommended air pressures.

Cracks in the wheel disc, between stud holes or hand holes. These are caused by loose wheel nuts, improper installation procedures and use of incorrect sizes or types of attaching parts.

Cracks through side ring, spreading laterally through the entire section. These are caused by improper mounting and demounting techniques, impact with road obstructions and excessive clamping torques.

Sprung side ring, resulting from improper mounting procedures.

Erosion and chipping of bead seat of lock ring, resulting from excessive corrosion. This may occur with this part as well as others if protective measures are not taken.

Replace damaged parts.

Ensure that replacements are made with the proper sizes and types of rims and rings.

Caution

Excessively corroded or cracked rims or rings can be dangerous. Deflate tires prior to the removal of rims or wheels from the vehicle.

Trouble-shooting wheel problems

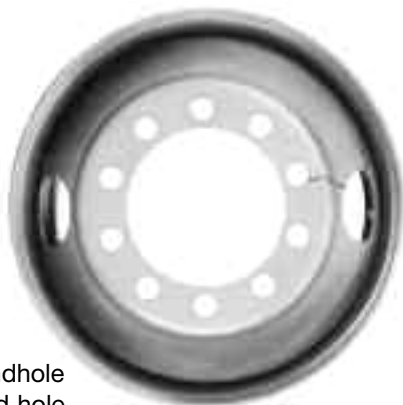

Problem:
Wheel cracks

- Handhole to handhole
- Handhole to stud hole
- Handhole to rim

Cause:
Overloading

Remedy:

- Check actual load on axle
- Install new wheel according to loading requirements.



Problem:
Wheel cracks

- Stud hole to stud hole

Cause:
Loose wheel nuts
Insufficient backup diameter

Remedy:

- Check for worn mating face on hub or drum
- Check for loose studs in hub
- Check for cracked or broken studs
- Replace any damaged parts
- Follow proper torque procedure described on page 23.

Spindle axle nut instructions

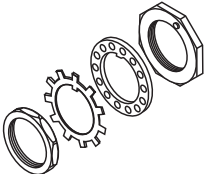
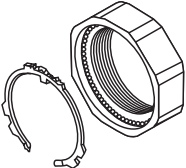
		SPINDLE THREAD	A. Lubricate spindle thread	B. Nut preparation	C. Inner Nut			
					Bolt	Un-bolt	Bolt	Release
2 NUTS SYSTEM 	HUB STD	Fine	yes	-----	+ 200 lbs-pi	-1 turn	+ 50 lbs-pi	- 1/4 turn
		Coarse						- 1/8 turn
	HUB CONMET PRESET	Fine or Coarse	yes	-----	+ 300 lbs-pi	No back off	-----	-----
PRO-TORQ NUT SYSTEM 	HUB STD	Fine	yes	Remove the keeper from the nut	-----	-----	-----	-----
		Coarse						-----
	HUB CONMET PRESET	Fine or Coarse	yes		-----	-----	-----	-----

D. Lock washer (Peak facing exterior)	E. Star washer	F. Outer Nut				G. Locking device	H. Acceptable end play (in)	I. Verification
		Bolt	Un-bolt	Bolt	Release			
yes	yes	+ 350 lbs-pi	No back off	-----	-----	Bend 2 stars of the star washer towards outer nut	0.001 to 0.005	Make sure that the wheel turns freely after each spindle nut tightening
yes	yes	+ 200 lbs-pi	No back off	-----	-----		0.000 to 0.004	
-----	-----	+ 200 lbs-pi	- Back off until it is loose	+ 100 lbs-pi (*5 times)	-1/10 turn (1/10= 1 stud) - ? turn	Install the keeper (orange side facing out). The keyway tang must be in the axle keyway	0.001 to 0.003	
-----	-----	+ 300 lbs-pi	No back off	-----	-----		0.001 to 0.003	

Wheels

Oil lubricated wheel bearing

Check hub gaskets and seals for oil leaks prior to each trip. Leaking seal can result in ruined wheel bearings and possible failure of the axle-wheel assembly.

Check oil level in hubs prior to every trip. Add oil when level is low, only to the level indicated by the mark on the hub cap. Too much oil can damage the wheel bearings. Use synthetic oil grade 50 (transmission), or an equivalent mineral oil based product.

Caution

Cracked wheels, loose lug nuts or missing studs are extremely hazardous conditions that are likely to cause accidents or breakdowns.

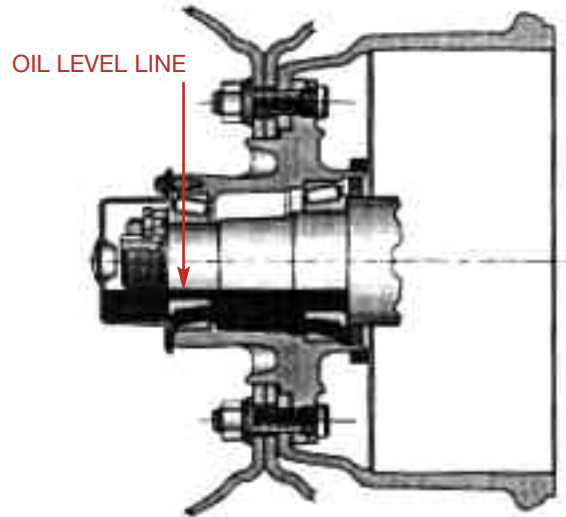

Grease or semi-fluid grease wheel bearing

Manac recommends, as a minimum, during routine PM service, to inspect the inner side of the hub for obvious leakage. Correct leakage problem if occurring. Also, it is necessary to insure, at every 60 000 miles, that the outer bearing is getting lubricated and that there is enough grease in the hub. This is especially important with the wheel-end systems using the smaller outer bearing. A visual inspection through the inspection plug or after removing the hubcap should be made. If inadequate grease is suspected (obvious lack of grease) pull the outer bearing to make sure of an adequate amount of grease. Replenish if necessary. If there is any sign of overheating or component damage, the wheel-end system should be redone.

Axle alignment

Axle alignment must be checked at regular intervals. If the semitrailer is not tracking properly, this should be reported to the Maintenance Department.

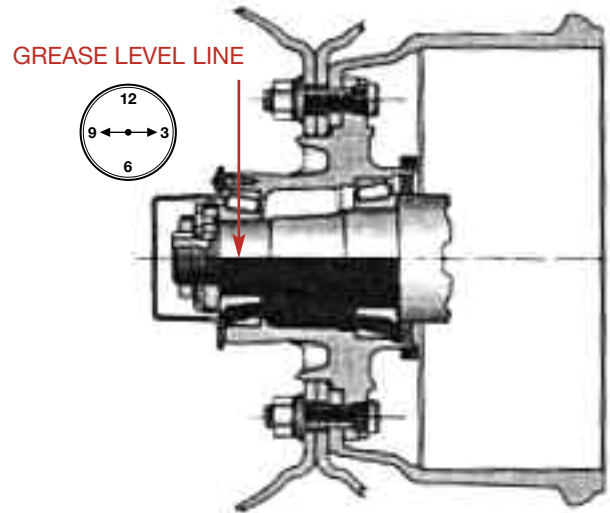

Leaf-spring suspension

Check the equalizer to see that there are no obstructions to movement during operation. If equalizer movement is restricted by an obstruction, the axle “walk” will not be sufficient and damage will result.

Check wear pads in hangers. If they are wearing thin, install new wear pads or the spring will cause permanent damage to the hanger itself. Do not operate with broken spring leaves.

Caution

Broken spring leaves, missing or loose U-bolts, or other defective conditions likely to cause axle shift, are hazardous and likely to cause accidents or breakdowns.

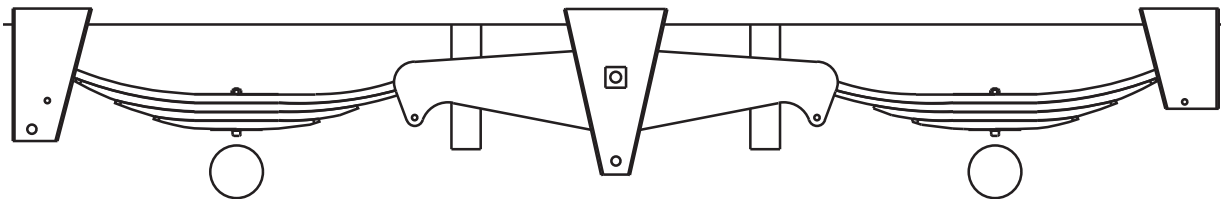

The air suspension height is controlled by a height control valve that maintains a constant semitrailer height by pressurizing or exhausting air in the air springs as needed to support the load being carried.

You must build up and maintain your semitrailer's air pressure higher than 65 psi before operating the semitrailer. The air protection valve won't operate until you have 70 psi in the system. This valve automatically maintains a safe air brake pressure higher than 70 psi to even air loss due to a failure in the suspension system.

If an air-spring failure occurs on one side, it is recommended to completely deflate the suspension and temporarily operate on the air spring's internal rubber bumpers, to allow your semitrailer to be moved to the nearest shop for repairs.

To deflate or cut off the air pressure to the damaged air spring, disconnect the height control valve actuating levers from their link assemblies and rotate to the vertical down position.

Caution

- Do not operate the vehicle without air pressure in the air springs.
- A semitrailer parked for any length of time with a payload and supported by the landing gear legs should be lowered on to the air spring internal bumpers.
- For safe loading and unloading, lower the vehicle on to the air spring internal bumpers.

Air suspension

Quad axle unit

According to regulations for quad axle unit, a ratio valve may be required. This ratio valve manages the ground pressure of the steering axle with the one of the tridem within 1 100 lbs. (500 KG). Check with your State, Province, and/or Territory authority to know the local requirements.

The ratio valves are factory-calibrated, however we recommend testing the calibration twice a year.

Calibration procedure:

- To Localize the ratio valve (part no 223-626) usually mounted close by steering-axle.
- Install gauge on optional gauge port.
- Loose lock nut.
- Read pressure of tridem suspension bag. (P)

- Use the pressure (P) multiply by factor (F) obtained from your Manac Service shop to find the ratio (R) pressure for your specific unit. ($P \times F = R$)
- Turn clockwise or counterclockwise the adjustment screw until reading the pressure (R) on optional gauge.
- Make sure to tighten lock nut.

Note: This procedure must be done with loaded unit.

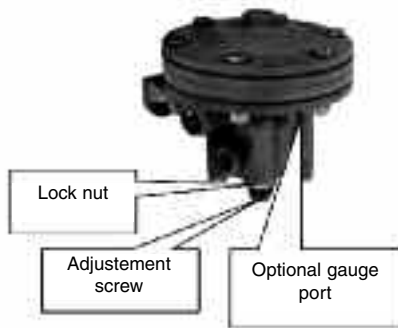

Suspension safety and inspection

Suspension inspection

During regular vehicle maintenance, visually inspect the following items:

- all fasteners including the pivot bolts and U-bolts for security as applicable to your suspension
- all welds including axle connection pivot, beam, bracket and frame attachment
- structure: integrity of vehicle frame, suspension beams and brackets
- broken or leaking shock absorbers
- air springs for chafing, rubbing, or damage
- air system valves, piping and fittings (see top figure)
- suspension ride height (see bottom figure)

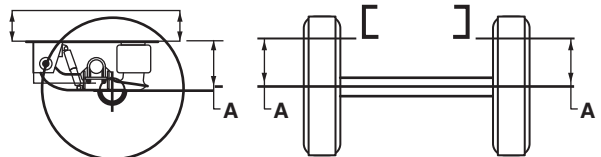
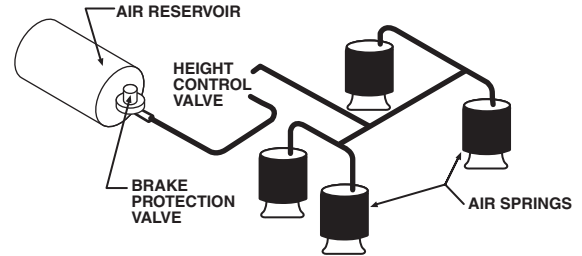

A = Ride height

Exhaust (dump) valve operation

In many cases, trailers that are equipped with air suspensions also incorporate valving that allows the suspension's air pressure to be exhausted (dumped) for loading, unloading or when the semitrailer is parked for a prolonged period of time. The following steps describe a typical sequence of operations involving the use of an automatically or manually controlled exhaust (dump) valve:

Prior To Loading, Unloading Or Prolonged Parking

Docking process

A- WITH auto reset

1. Once the semitrailer has been backed up to the loading dock, apply the semi-trailer's parking brakes.
2. Manually activate the exhaust valve inside control box. Begin the loading/unloading process as usual.

B- WITHOUT auto reset

1. Before backing up to the loading dock, manually activate the exhaust valve.
2. Back the semitrailer up to the loading dock, allowing the suspension to drain as you move backwards.
3. Apply the semitrailer's parking brakes after the air pressure has been completely drained; chock the semitrailer wheels and begin the loading/unloading process as usual.

Note

Note 1: If the semitrailer is equipped with an automatic exhaust valve, air in the suspension will be drained at the parking brakes application.

Exhaust (dump) valve operation

Drive-out process

1. Couple the tractor and semitrailer, if needed.
2. Raise the support legs, if needed, prior to inflating the suspension's air spring (bags).
3. Activate the exhaust (dump) valve.
4. Unchock the wheels, release the parking brakes and pull away from the loading dock after the semi-trailer reaches normal operating height.

Note

Note 2: If the semitrailer is equipped with an auto-reset valve, air pressure in the bags will settle after taking off the parking brakes.

Note 3: If the semitrailer is equipped with an automatic exhaust valve, air pressure in the bags will settle after taking off the parking brakes.

Reporting safety defects

If you believe that this vehicle contains a safety defect, you may contact the manufacturer, NHTSA or both.

This vehicle was designed and quality inspected to conform with industry standards and all applicable National Highway Traffic Safety Administration safety standards. Manac warrants this vehicle to be free from defects in materials and workmanship when manufactured. If you detect a defect that could cause an accident or could cause injury or death, you should advise:



Oran, MO

8593 State Highway 77

P.O. Drawer K

Oran MO 62771 USA

Toll free: 1 800 545-5086

T. : 573 262-2166

F. : 573 262-3480

If you believe your vehicle has a defect which could cause a crash or could cause injury or death, you should immediately inform the National Highway Traffic Safety Administration (NHTSA) in addition to notifying Manac.

If NHTSA receives similar complaints, it may open an investigation and if it finds that a safety defect exists in a group of vehicles, it may order a recall and remedy campaign. However, NHTSA cannot become involved in individual problems between you, your dealer, or Manac.

To contact NHTSA you may either call the Auto Safety Hotline, toll free, at 1 (800) 424-9393 (or 202-366-0123) in Washington, D.C. area or write to: NHTSA, U.S. Department of Transportation, Washington, D.C. 20590. You can also obtain other information about motor vehicle safety from the Hotline.

Oran, MO

8593 State Highway 77

P.O. Drawer K

Oran MO 62771 USA

Toll free: 1 800 545-5086

T. : 573 262-2166

F. : 573 262-3480



●●manac

WHATEVER THE ROAD