

Construction Trailer Specialists, Inc.

Operating Manual

Version 1.1

CONSTRUCTION
TRAILER
SPECIALISTS ©©

Table of Contents

1	Coupling and Uncoupling	5		
	Coupling	5		
	Uncoupling	8		
	Steps and Handholds	10		
	Normal Use	11		
2	Pre-Trip Inspection	12		
3	Prevent Trailer Rollover	15		
	Loading and Unloading Trailer	15		
	Stability	15		
	Factors Adversely Affecting Stability	15		
	Hazard Control	16		
	Maintenance	17		
	Dumping	17		
4	Tire Loads	18		
5	Trailer Service Information	20		
	Inspection Service/Preventive Maintenance	20		
	Axle Bolts, Frame, Suspension and Structure	20		
	Leaf Spring Suspensions	20		
	Inspecting for Cracks	20		
	Air Ride Suspensions	20		
	Tires and Wheels	21		
	Wheel Bearings and Axle Alignment	22		
	Tires	22		
	Welds	22		
	Frame Members and Fasteners	23		
	Brake Shoes and Drums	23		
	Air Controls or Air Cylinder	23		
	Door Lubrication	23		
	Lights and Electrical System	24		
	Hydraulic Powered Cylinder	24		
6	Bottom Dump Trailer Service Information	26		
	Air Filter Preventive Maintenance	26		
	Oiler Filter Preventive Maintenance	26		
	Door Adjustment	27		
	Servicing the Door	27		
	Repair of a Rexroth Solenoid	28		
7	Wiring Diagrams	29		
8	Warning Labels	32		
9	Warranty Information	35		

Operator's Instructions

This manual has been prepared to assist you in maintaining the safety, dependability, and performance built into every Construction Trailer Specialists, Inc. trailer. It is essential that this trailer receives periodic inspections, maintenance, and service parts replacement.

This manual includes safety checks the operator must perform periodically.

It is important every trailer owner and/or operator have an organized Trailer Preventive Maintenance (TPM) program. In addition, the United States Department of Transportation requires maintenance records be kept on every commercial highway vehicle. It is to your advantage to show regularly scheduled TPM inspection checks have been made on every piece of equipment operated. A regular TPM program will assure you get the most from your Construction Trailer Specialists, Inc. trailer.

You can get help setting up your Trailer Preventive Maintenance program by going to the Truck Trailer Manufacturers Association website at www.ttmanet.org. There you can select a number of RPs (Recommended Practices) or TBs (Technical Bulletins) to assist you. For further assistance, please call TTMA at (703) 549-3010.

In addition to this Operating Manual, there is a set of informational manuals supplied with your trailer from the manufacturers of the various components used to build your trailer including, but not limited to:

- ◆ Hutchens Suspensions (www.hutchensindustries.com)
- ◆ Meritor Wabco Brake System (www.meritorwabco.com)

Please read these manuals carefully as they contain detailed information on these different trailer components as well as vital safety and maintenance information.

IMPORTANT

Read this manual carefully. Should you have any questions, please contact Construction Trailer Specialists, Inc. at 888-669-0003 or email us at info@trailerbuilders.com. This manual should be kept with the trailer at all times and should remain with the trailer when it is sold. Replacement manuals can be obtained at www.constructiontrailerspecialists.com.

COUPLING AND UNCOUPLING

Knowing how to couple and uncouple your trailer correctly is basic to the safe operation of combination vehicles. General coupling and uncoupling steps are listed below. Keep in mind that there may be differences between various combinations of tractors and trailers. Learn the specific details of coupling and uncoupling the vehicles you will operate.

WARNING
INCORRECT COUPLING AND UNCOUPLING CAN RESULT IN SERIOUS INJURY OR DEATH.

Coupling Tractor Semi Trailers

Step 1: Inspect Fifth Wheel

- ◆ Check for damaged and/or missing parts.
- ◆ Check to see that mounting to tractor is secure, no cracks in frame, etc.
- ◆ Be sure the fifth wheel plate is lubricated as required. Failure to keep the fifth wheel plate lubricated could cause steering problems and/or damage to the trailer due to friction between the tractor and the trailer.

WARNING
ADVERTENCIA

THE USE OF A LUBE PLATE OR SLICK PLATE MAY ALTER THE KING PIN DIMENSIONS FROM SAE STANDARDS (SAE J700B) PREVENTING PROPER COUPLING AND CAUSING DAMAGE TO THE KING PIN!

FOLLOW SAE STANDARDS DURING INSTALLATION AND OPERATION OF THIS KING PIN

EL USO DE UNA PLACA LUBE O PLACA PULIDA PUEDE ALTERAR LAS DIMENSIONES KING PIN CONFORME A LAS NORMAS SAE (SAE J700B) PREVIENDO EL ACOPLAMIENTO ADECUADO Y CAUSANDO DAÑOS AL PIN REY

SEGUIR LAS NORMAS SAE DURANTE INSTALACIÓN Y FUNCIONAMIENTO DE ESTE REY PIN

- ◆ Check if fifth wheel is in proper position for coupling:
 - Wheel tilted down towards rear of tractor.
 - Jaws open.
 - Safety unlocking handle in the automatic lock position.
- ◆ If you have a sliding fifth wheel, make sure it is locked in place.
- ◆ Make sure the trailer kingpin is not damaged.
- ◆ If any damage is found, remove the vehicle from service immediately.

Step 2: Inspect Area

- ◆ Make sure the area around the vehicle is clear.
- ◆ Be sure trailer parking brakes are applied.

- ◆ Check that the door(s) are brought back to the locked position and locks have been secured. Verify the tarp is secured in the correct position. If pulling a bottom dump trailer, ensure the slide lock is in the locked position. See page 27 for additional information on slide locks.

Step 3: Position Tractor

- ◆ Back the tractor directly in front of the trailer. Never back under the trailer at an angle, as you may push the trailer sideways and damage the support legs.
- ◆ Check position, using outside mirrors, by looking down both sides of the trailer.

Step 4: Back Slowly

- ◆ Back up until the fifth wheel just touches the trailer.
- ◆ Do not hit the trailer.

Step 5: Secure Tractor

- ◆ Put on the parking brake.
- ◆ Put transmission in Neutral.

Step 6: Check Trailer Coupler Height

- ◆ The trailer should be low enough that it is raised slightly by the tractor when the tractor is backed under it. Raise or lower the trailer as needed. If trailer is too low or too high, tractor may strike and

damage the nose of the trailer, or it may not couple correctly.

- ◆ Check that the kingpin and fifth wheel are aligned.

Step 7: Connect Air and Electrical Lines to Trailer

- ◆ Check coupler seals and connect tractor supply (emergency) airline to trailer supply (emergency) coupler (see pg. 13, fig. 5 & 6).
- ◆ Check coupler seals and connect tractor control (service) airline to trailer control (service) coupler.
- ◆ Make sure air lines are safely supported where they will not be crushed or caught while tractor is backing under the trailer.
- ◆ Plug the electrical cord into the trailer and fasten the safety catch.
- ◆ Check both airlines and electrical lines for signs of damage. Repair or replace if necessary.
- ◆ Make sure air and electrical lines will not hit any moving parts of vehicle.

Step 8: Supply Air to Trailer

- ◆ From cab, push in "Air Supply" knob or move tractor protection control valve from the "Emergency" to the "Normal" position to supply air to the trailer brake system.
- ◆ Wait until the air pressure is normal.

WARNING

ABS MALFUNCTION INDICATOR LAMP SHOULD TURN ON AND OFF WHEN THE ELECTRICAL POWER IS INITIALLY APPLIED TO THE ANTILOCK BRAKE SYSTEM. IF THE LAMP DOES NOT TURN ON, IT MAY BE DEFECTIVE AND MUST BE REPAIRED. IF THE LAMP TURNS ON AND REMAINS ON WHILE POWER IS APPLIED WITH TRAILER IN MOTION, THE SYSTEM MUST BE REPAIRED BY A COMPETENT SERVICE FACILITY. FAILURE TO FOLLOW THIS WARNING CAN RESULT IN PROPERTY DAMAGE, SERIOUS INJURY OR DEATH.

- ◆ Check brake system for crossed air lines.
 - Turn engine off so you can hear leaks in the brake system.
 - Apply and release trailer brakes. Listen for sound of trailer brakes being applied and released. You should hear the brakes move when applied and air escape when the brakes are released.
 - Check air brake system pressure

gauge for signs of air loss.

- ◆ When you are sure trailer brakes are working, start engine.
- ◆ Make sure air pressure is up to normal.

Step 9: Lock Trailer Brakes

- ◆ Pull out the "Air Supply" knob, or move the tractor protection control valve from "Normal" to "Emergency."

Step 10: Back Under Trailer

- ◆ Use lowest reverse gear.
- ◆ Back tractor slowly under trailer to avoid hitting the kingpin too hard.
- ◆ Stop when the kingpin is locked into the fifth wheel.

Step 11: Check Connection for Security

- ◆ Raise trailer support legs slightly off ground.
- ◆ Pull tractor gently forward while the trailer brakes are still applied to ensure secure connection.

Step 12: Secure Tractor-Trailer

- ◆ Put transmission in Neutral.
- ◆ Put parking brakes on.
- ◆ Turn off engine and take the key with you so someone else cannot move the tractor-trailer while you are under it.

Step 13: Inspect Coupling

- ◆ Use a flashlight if necessary.
- ◆ Make sure there is **no space between upper coupler and fifth wheel**. If there is space, something is wrong (i.e., kingpin may be on top of closed fifth wheel jaws; trailer can come loose easily).
- ◆ Go under trailer and look into the back of the fifth wheel. Make sure the fifth wheel jaws have closed around the shank of the kingpin.
- ◆ Check that the locking lever is in the "Lock" position.
- ◆ Check that the safety catch is in position over locking lever. On some fifth wheels the catch must be put in place by hand.
- ◆ If the coupling is not right, **do not drive the coupled unit**. Get it fixed.

Step 14: Raise Support Legs/ Landing Gear

- ◆ Use low-gear range (if so equipped) to begin raising the support legs. Once free of weight, switch to the high-gear range.
- ◆ Raise the support legs all the way up. Never drive with support legs partially raised as they may catch on railroad tracks or other things.
- ◆ After raising the support legs, properly secure the crank handle.
- ◆ With the front of the trailer supported by the tractor, check for

enough clearance between rear of tractor frame and support legs. When tractor turns sharply it must not hit the support legs or their bracing.

- Check that there is adequate clearance between the top of the tractor tires and the underside of the trailer.
- Always use chock blocks and lock trailer brakes when uncoupling or coupling tractor and trailer. Chock as required in unusual conditions.

! WARNING

THE SUPPORT LEGS ARE NOT INTENDED TO SUPPORT A LOADED TRAILER.

Uncoupling Tractor Semi Trailers

Step 1: Position Rig

- ◆ Make sure surface of parking area can support weight of trailer.
- ◆ Have tractor in a straight line with the trailer. Pulling out at an angle can damage the support legs and upper coupler.

Step 2: Ease Pressure on Locking Jaws

- ◆ Shut off trailer air supply to lock trailer brakes.
- ◆ Ease pressure on fifth wheel locking jaws by backing up gently. This will help you release the fifth wheel locking lever.
- ◆ For trailers equipped with an air ride suspension, release air from air bags.
- ◆ Apply parking brakes while tractor is pushing against the kingpin. This will hold the tractor with pressure off of the locking jaws.

Step 3: Lower the Support Legs

- ◆ Lower the support legs until they make firm contact with the ground. Turn crank (in low gear) a few extra turns. This will lift some weight off the tractor. Do not lift trailer off the fifth wheel. This will make it easier to unlatch fifth wheel and couple next time.

Step 4: Disconnect Air Lines and Electrical Cable

- ◆ Disconnect air lines from trailer. Connect airline couplers to dummy couplers at the back of the cab.
- ◆ Hang electrical cable with plug down to prevent moisture from entering.
- ◆ Make sure lines are supported so they will not be damaged while

driving the tractor.

Step 5: Unlock Fifth Wheel

- ◆ Raise release handle lock.
- ◆ Pull the release handle to "Open" position.
- ◆ Keep legs and feet clear of the rear tractor wheels to avoid serious injury if the vehicle moves.

Step 6: Pull Tractor Partially Clear of Trailer

- ◆ Pull tractor forward until fifth wheel comes out from under the trailer.
- ◆ Stop with tractor frame under trailer to prevent trailer from falling to ground if support legs should collapse or sink.

Step 7: Secure Tractor

- ◆ Apply parking brake.
- ◆ Place transmission in Neutral.

Step 8: Inspect Trailer Support

- ◆ Make sure ground is supporting trailer.
- ◆ Make sure support legs are not damaged.

Step 9: Pull Tractor Clear of Trailer

- ◆ Release parking brakes.
- ◆ Check and drive tractor clear.

Steps & Handholds

Use all steps and handholds with extreme caution. Such components are subject to wear, damage and environmental conditions. Make sure these components are firmly attached and properly maintained.

If you suspect they are not, do not use them. If steps are wet, iced or for any reason seem to be slippery, do not use them.

Climbing Practices

- ◆ Store clipboards and all other objects prior to climbing. Hands must be free.
- ◆ Face inward (toward the trailer) at all times while ascending and descending.
- ◆ Maintain a three-point contact at all times.
- ◆ Wear slip-resistant footwear.

Access From The Ground

Use the front wall steps only when the trailer is properly supported by extended support legs. You must use a step ladder, or other structure specifically designed for the purpose of ascent and descent and of an adequate height to safely reach the bottommost step.

Access From The Tractor

If the tractor is not equipped with adequate steps, handholds and slip-

resistant deck plate to the rear of the cab, **do not attempt access to the trailer steps from the tractor.** Use "Access From The Ground" method. If the tractor is properly equipped with steps, handholds and a deck plate and the tractor is coupled and locked to the trailer, it is most important that the tractor be in a partial "jackknife" orientation. The tractor must be positioned such that the deck plate is directly beneath the lowest step.

- ◆ **DO NOT** climb on steps not firmly attached and properly maintained.
- ◆ **DO NOT** climb on steps with anything in your hands.
- ◆ **DO NOT** use a tractor not equipped with a safe, adequate climbing system to access the trailer's front steps.
- ◆ **DO NOT** step on tires, fenders, frames, tarp headers and bows or mud flap supports.
- ◆ **DO NOT** step over air and electrical lines between the tractor and trailer. Disconnect and properly store, if necessary.
- ◆ **DO NOT** use any portion of the tractor in conjunction with any portion of the trailer simultaneously in a "spread-eagle" hold or stance for support.
- ◆ **DO NOT** use an access system if wet, iced, or for any reason seems to be slippery.

- ◆ **DO NOT** stand on trailer's access system while the trailer is being coupled or uncoupled.
- ◆ **DO NOT** jump from the trailer to the ground.

Normal Use

This Construction Trailer Specialists, Inc. trailer was designed for operation within legal highway speed limits on reasonable road surfaces in accordance with the following:

1. This trailer was built to carry a payload within the limitations of weight ratings shown on the certification label, or VIN tag. These ratings, GAWR and GVWR are:
 - The GAWR (Gross Axle Weight Rating) is the structural capability of the lowest rated member of the running gear components: suspension system, hubs, wheels, drums, rims, bearings, brakes, axles, or tires.
 - The GVWR (Gross Vehicle Weight Rating) is the structural capability of the trailer when supported by the upper coupler and axles with the load uniformly distributed throughout the cargo space. CAUTION! The maximum load indicated on the certification label may or may not be a legal load on the highway you plan to use.
2. The trailer will carry a total payload equal to the Gross Vehicle Weight Rating (GVWR) less the weight of the trailer. The load must be uniformly distributed.

MFD BY: CONSTRUCTION TRAILER SPECIALISTS

DATE: 12/2015

GVWR: 30844 KG (68000 LB)

GAWR (EACH AXLE): 10297 KG (22700 LB)

WARNING

Operation of the trailer outside the limitations of this manual is against federal law and Construction Trailer Specialists Inc. design criteria. Any operation exceeding the limitations stated will void any responsibility of Construction Trailer Specialists, Inc. for the results.

PRE-TRIP INSPECTION

⚠️ WARNING

When you make inspections, hookups or repairs, be careful how you position your body. The trailer or tractor might move unexpectedly and cause serious injury or death.

Your trailer **MUST** be inspected **BEFORE** each trip, **DURING** the trip and at the **END** of each trip.

While the responsibility for checks and adjustments of a trailer may belong to the shop or maintenance department, an operator must never take the condition of a tractor or trailer for granted. For the operator's own safety, as well as the safety of others, and in accordance with Federal Motor Carrier Safety Administration (FMCSA, Section 396) and CDL Class A requirements, it is necessary to make thorough pre-trip and post-trip inspections as well as on-the-road observations and written reports of the equipment.



Fig. 1



Fig. 2



Fig. 3

Inside Cab

1. Apply parking brake and start engine. (Fig. 1)
2. Check oil pressure, warning lights and air pressure. Deplete air pressure until warning buzzer sounds. (Fig. 2 & 3)

Approaching the tractor and trailer

Look for oil, water, air or other leaks.



Fig. 4



Fig. 5



Fig. 6



Fig. 7

Leave cab (engine running) and walk toward rear

1. Examine tractor and trailer wheels, lug nuts and tires. Check tires for proper inflation and abnormal wear. Ensure lug nuts are torqued to recommended torque. (Fig. 4)
2. Wheel lug nuts on new wheels can shift and settle quickly after being assembled. Be sure to inspect the torque of the lug nuts after the first 50-100 miles of driving. (Fig. 4)
3. Ensure electrical and air connectors are firmly seated and cords/hoses are free from chafing. (Fig. 5 & 6)
4. Be sure landing gear or drop legs are raised and any handle is securely stowed in the crank handle holder before attempting to move the trailer. (Fig. 7)

⚠️ WARNING

Re-torque wheel nuts to 450-550 LB-FT after initial 50-100 miles of service and daily thereafter. Failure to do so may result in equipment damage, personal injury or death.



Fig. 8



Fig. 9



Fig. 10



Fig. 11

5. Make sure fifth wheel is locked. (Fig. 8)
6. Inspect and clean side marker lights and reflectors. (Fig. 9)
7. Inspect and clean conspicuity tape. (Fig. 10)
8. Make sure all lights are working properly and clean as required. (Fig. 11)
9. Ensure all doors on trailer are securely locked.

Hubs

Check hub gaskets and seals for leaks before each trip. A leak in a hub can result in damage to the wheel bearings and possible failure of the

axle and wheel assembly. Check oil level in hubs before every trip. Add oil when low. Fill only to the level indicated by the mark on the hub cap. Too much oil can damage the wheel bearings. Use appropriate oil or grease as recommended by the axle manufacturer.

Back in cab

With trailer brakes still on, release tractor brakes and (in first gear) gently engage clutch to test tractor-trailer coupling. Apply foot brake for one minute. Air loss should not exceed 4 psi per minute for combination rig.

PREVENT TRAILER ROLLOVER

These instructions **MUST** be followed to maximize trailer stability and minimize rollover hazard. Any cargo movement under adverse handling conditions, such as an accident avoidance maneuver or dumping, may cause vehicle instability and result in rollover.

Loading and Unloading Trailer

DO NOT overload trailer. See certification plate for Gross Vehicle Weight Rating (GVWR) and Gross Axle Weight Rating (GAWR).

Your Construction Trailer Specialists, Inc. trailer is specially designed for hauling a payload that is to be dumped. Loading of the trailer from front-to-back must meet allowable gross weight and axle weight limitations.

If material is likely to flow poorly, lighten up the load in the front end of the trailer. A slightly smaller load will be better than a full load that causes a tip-over.

Stability

ALL end dump trailers will tip over if not operated properly. Only operators with **significant training** with end dumps should be allowed to

operate an end dump trailer.

When the center of gravity of the load is not evenly distributed in the box or tub, there is a risk of tip-over.

Factors Adversely Affecting Stability

Many things can adversely affect the stability of a dump trailer when dumping, including but not limited to:

- ◆ The unit is not on a solid foundation and not on solid ground when dumping.

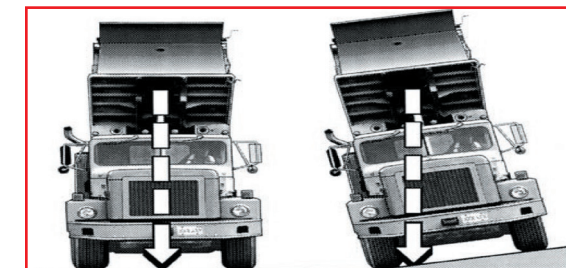

! WARNING

When the center of gravity of the box/tub and load are not centered between the frame rails and/or the suspension of the unit, there is a risk of tip-over.

- ◆ A large amount of material is in the upper portion of the raised box.
- ◆ Material does not flow out of the top portion of the trailer, or does not flow out of one side of the trailer.
- ◆ The rear wheels settle unevenly as the load moves to the rear while dumping.
- ◆ Wind may cause lateral shifts in loads, especially if the trailer is long, as is the case with most end dump semi-trailers.
- ◆ Overloading
- ◆ Improper weight distribution; from side to side and front to back.
- ◆ Modifying or altering hydraulics or air components.
- ◆ Modifying or altering dump controls.
- ◆ Not fully opening doors when dumping.
- ◆ Jerking the trailer or hydraulics to loosen the load.
- ◆ Trailer coming near or contacting overhead power lines or bridges when the body is raised.
- ◆ Cold weather may cause materials to freeze to the box or tub and stick when dumping. During winter, loads should not be left overnight, or for long periods of time.

Trailer stability can also be affected by mechanical conditions, including but not limited to:

- ◆ Poor rear suspension systems on one side of the vehicle.
- ◆ Uneven tire pressures in rear wheels.
- ◆ Worn or inadequate components of the lifting system such as pins; or worn or inadequate lifting cylinders.
- ◆ If any of these conditions exist, **DO NOT** operate or attempt to dump the trailer. **REMOVE** the trailer from service immediately.

After the trailer is dumped and the door(s) are brought back to the locked position, visually check that the locks have been secured.

WARNING

The trailer should **NEVER** be jerked or rocked with the tractor or hydraulics to loosen the load as the trailer may tip over causing serious injury or death.

Hazard Control

In order to maintain the stability and minimize the chance of tipping over an end dump semi-trailer, it should never be used for hauling

to rough graded or fill areas where surfaces are often uneven or loosely compacted. Always select the appropriate equipment to fit the task being done in order to reduce the chance of tip-overs.

Maintenance

Preventive maintenance can also play an important role in preventing vehicle tip-overs.

- ◆ Check tire pressures daily. Tire pressure should be equal on each side of the vehicle and trailer and in accordance with the manufacturers' recommendations.
- ◆ Examine and lubricate pins and bushings regularly.
- ◆ Inspect suspension systems under load to ensure they work properly and provide even suspension. Weak suspension systems should be replaced immediately.
- ◆ Inspect hoist cylinders regularly. Worn cylinders must be replaced with a cylinder of the same size and rating.
- ◆ Any repairs to boxes/tubs must be done by Construction Trailer Specialists, Inc. or an authorized repair facility and must leave bottom and sides clear and unrestricted. Rough patchwork repairs near the top of the box can catch and hold sticky materials.

Dumping

Operators must be trained to recognize hazardous dumping conditions, such as soft or uneven surfaces and inadequately compacted fill.

- ◆ Before dumping, operators should ensure the tailgate is unlocked and the vehicle is on a level surface. Dumping on surfaces that are not level is one of the primary causes of tip-overs.
- ◆ Before spreading material by dumping it from a moving truck, make sure the entire length of travel is level.
- ◆ Trucks should not dump when they are parked next to another vehicle. When a dump unit tips over, it is often the operator in the adjoining vehicle that is injured.
- ◆ Dumping operations should be spread out to avoid possible injury.
- ◆ Other personnel such as dozer operators, surveyors, and spotters should never work near a dumping trailer.
- ◆ Workers should not congregate in areas where dumping is under way.

TIRE LOADS

Do not overload the trailer tires. Overloading tires creates a dangerous and unsafe condition that must be avoided.

The total load per tire must not exceed the tire manufacturer's specified load carrying capacity at stated inflation pressures for both tires and rims. Construction Trailer Specialists, Inc., as required by the safety regulations of the National Highway Traffic Safety Administration, has assigned a Gross

Axle Weight Rating (GAWR) for each axle on the VIN plate as shown below.

The GAWR and tire information shown on the VIN plate was applicable at the time the trailer was manufactured. If the tires or other components of the running gear have been changed or altered since the trailer was manufactured, the GAWR may have changed.

MFD BY: CONSTRUCTION TRAILER SPECIALISTS		DATE: 12/2015	
GVWR: 30844 KG (68000 LB)	GAWR (EACH AXLE): 10297 KG (22700 LB)		
COLD INFLATION PRESSURE			
TIRE	RIM	KPA (PSI)	SGL/DUAL
22.5	8.25	827 KPA (120 PSI)	DUAL
THIS VEHICLE CONFORMS TO ALL APPLICABLE U.S. FEDERAL MOTOR VEHICLE SAFETY STANDARDS IN EFFECT ON THE DATE OF MANUFACTURE SHOWN ABOVE.			
V.I.N.		TYPE OF VEHICLE	
		TRAILER BDT 40	

Tires and wheels

Proper installation of tires and wheels on a vehicle is essential to safe, economical and trouble-free service. Use only the specified sizes of studs, nuts and clamps.

Check metal surfaces thoroughly, including area between duals and on inboard side of wheel. Watch for:

◆ Excessive rust or corrosion buildup

- ◆ Cracks in metal
- ◆ Bent flanges
- ◆ Deep rim tool marks on rings or in gutter areas
- ◆ Loose, missing or damaged nuts or clamps
- ◆ Bent or stripped studs
- ◆ Damaged or missing rim drive plates
- ◆ Mismatched rim parts

Check all parts for damage, including wheels and rings. Ensure that studs, nuts and mounting faces of hub and wheels are clean and free from grease. Replace any defective parts. Mount single wheel or inner dual wheel (also, outer dual wheel for hub-type mounting) over studs, being careful not to damage stud threads. Do not

tighten fully the first time around. When all lug nuts are snug, torque each nut to between 450 and 550 lb-ft of torque. When mounting a dual set follow the same process. In each case, be sure to tighten wheel nuts only to the torque level recommended. Over torquing can cause damage to the rim, studs, nuts and/or threads.

Tighten lug nuts fully, using the same alternate sequence. In each case, be sure to tighten lug nuts only to the torque level recommended below and to maintain them at that level through planned, periodic checks.

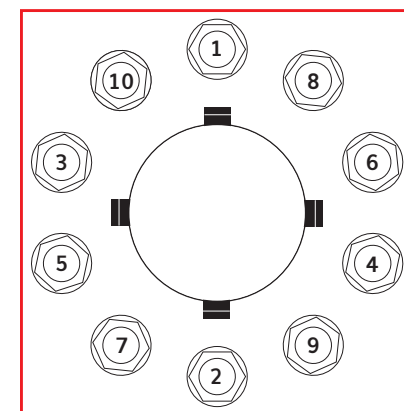

Tighten lug nuts alternately in the sequence as shown. This procedure will permit the uniform seating of nuts and ensure the even face-to-face contact of wheels and hub.

! WARNING

Recommended tightening torque for wheel mounting nuts is 450-550 lb-ft. This applies to hub-pilot mounting systems with 3/4-16 or M22 x 1.5 Studs for aluminum and steel wheels. Check lug nuts frequently (50-100 miles after initial in-service date and daily thereafter) to maintain the recommended torque. During this "settling in" period, lug nuts can lose up to 50% of their torque. Failure to heed this warning can result in property damage, serious injury or death.

TRAILER SERVICE INFORMATION

Inspection Service and Preventive Maintenance

You must inspect, maintain and service your trailer regularly to ensure safe and reliable operation. If you cannot, or are unsure how to perform these items listed, have your dealer do them prior to operation or call Construction Trailer Specialists, Inc. for guidance. You may also need to check the relevant component manufacturer's manual (see links to manufacturer's websites on page 4).

Axle Bolts, Frame, Suspension and Structure

Have the trailer professionally inspected annually and after any accident and/or misuse. The trailer should be examined for any worn or broken suspension parts and to verify the trailer is in alignment and dumps properly. Ensure the U-Bolt on the axle is tight so the weld doesn't break. If there are any worn or broken suspension parts the trailer should be taken out of service immediately.

Leaf Spring Suspensions

On trailers with two or more axles, check the equalizer to see that there is nothing to stop or prevent movement during operation. If equalizer movement is restricted by an obstruction, the axle will "walk" and damage will occur. Check wear pads in the hanger areas. If they are wearing thin, install new wear pads or the spring will cause permanent damage to the hanger itself. If a trailer has broken springs, the trailer should be taken out of service immediately.

Inspect Trailer for Cracks

Inspect the trailer for cracks in welds, tubes or steel prior to each use. Welds can crack or fail when subjected to wear, heavy loads, overloads and movement of cargo. Prior to each use and any time you know or suspect the trailer has been subjected to overloading or movement of cargo, immediately inspect the welds, trailer and fasteners for damage. To prevent severe damage to your trailer, inspect your trailer for cracks or failure prior to each use. If any

cracks are found, the trailer should be taken out of service immediately.

Air Ride Suspensions

The air ride suspension height is controlled by a height control valve that maintains a constant semi-trailer height by pressuring or exhausting air in the air bags as needed to support the load being lifted. The air pressure must be built up to at least 70psi before operating the semi-trailer and this pressure must be maintained during operation. The air protection valve will not operate until you have 70psi in the system. The valve automatically maintains a safe air braking pressure higher than 70psi to even air loss due to failure in the suspension system. If an air bag failure occurs, it is recommended to completely deflate the suspension and temporarily operate on the air bag's internal rubber bumpers, only long enough to allow your trailer to be moved to the nearest dealer or repair shop. To deflate the air pressure from the damaged air bag, disconnect the height control valve actuating lever from the link assembly and rotate to the vertical down position.

Tires and Wheels

Check all parts for damage, including wheels and ring clamps. Ensure the studs, nuts, and mounting faces of the hub and wheels are clean and free from grease. Replace any defective parts.

Check for wheel cracking and worn mating face on hub or drum.

WARNING

Do not inter-mix wheel types. Insufficient mounting torque can cause wheel shimmy resulting in damage to parts and extreme tire tread wear. Excessive mounting torque can cause studs to break and discs to crack in the stud hole area. Both cases could result in serious injury or death.

	WARNING ADVERTENCIA
	Always use properly matched wheels, studs, brake drums and capnuts. Failure to do so may result in equipment damage or personal injury. Siempre utilice ruedas correctamente emparejadas, clavos, tambores de freno y tuercas. El no hacerlo puede resultar en daños o lesiones personales.

Check for loose studs in hub as well as broken or cracked studs and replace any damage parts prior to operation.

Wheel Bearings and Axle Alignment

Check hub gasket and seals for leaks prior to each trip. Leaking seals can result in damaged wheel bearings and possible failure of the axle assembly. Check levels in each hub prior to every trip. Add when level is low, only to level indicated by the mark on the hub cap. Too much oil can damage the wheel bearings.

As a preventive maintenance precaution, inspect all of the inner sides of the hub for leakage at least once a year or every 60,000 miles, whichever comes first. Axle alignment also must be checked at regular intervals. If the semi-trailer is not tracking properly, it should be taken out of service immediately.

Tires

Trailer tires may be worn out even though they still have plenty of tread on them. This is because trailer tires carry a lot of weight all the time, even when not in use. The main cause of tire failure is

improper inflation. Tire pressure should be checked prior to each use as part of the pre-trip inspection. Always make sure tires are inflated to the pressure as recommended by the tire manufacturer. The pressure must be checked while the tire is cool. Do not check the tire immediately after towing the trailer.

Wheel and tire manufacturers recommend adjusting the air pressure to the maximum PSI listed on the sidewall of the tire when the trailer is fully loaded. If the tires are inflated to less than the maximum inflation level, the load carrying capacity of the tire could be affected. Tires can lose air over time. A drop in tire pressure could cause the tire to become overloaded leading to excessive heat build-up. If the tire is under-inflated, even for a short period of time, the tire could suffer internal damage. Driving at a higher speed can cause internal damage to the tire.

Do a pre-trip check on the tires and tire air pressure and look for worn, damaged or improperly inflated tires and replace worn out tires immediately as it may cause serious injury or death.

While checking inflation pressures, it is a good time to inspect your

tires. Any time you see any damage to your tire or wheels/rims, the trailer should be taken out of service immediately.

Frame Members and Fasteners

Prior to each use, inspect all fasteners and structural frame members for bending and other damage, cracks and/or failure. Repair or replace any damaged parts. Contact Construction Trailer Specialists, Inc. or an authorized dealer if you have any questions about the condition of your trailer, method of repair, or if a scheduled repair is required.

Brake Shoes and Drums

Properly working brake shoes and drums are essential to ensure safety. You must have your authorized dealer inspect these components at least once per year, or each 12,000 miles, whichever comes first.

The brake shoes must be adjusted after the first 200 miles of use and each 3,000 miles thereafter. Most axles are fitted with a brake mechanism that will automatically adjust the brake shoes when the trailer is "hard braked" while backing up. If you have any questions contact your authorized

dealer or Construction Trailer Specialists, Inc.

Air Controls and Air Cylinder

All air controls need to be checked prior to each use to ensure they have not vibrated loose. If they are loose, secure them into place.

Air controls and/or air cylinders over time will become slow to operate. This is due to the air in the tractor system that may need to be filtered on the tractor or a filter changed. The air controls or cylinders may also need to be cleaned or replaced.

Door Lubrication

Each door has a hinge, and in or on the hinge there will be grease zerks. These grease zerks need to be filled or recharged every 6 months or less, depending on operating conditions, with grease. When checking the grease zerks make sure the trailer is in a lock out situation and that the keys are removed from the tractor when performing this procedure.

Each trailer will also have cylinder mount grease zerks, which will need to be filled or recharged with grease every 6 months or less, depending on operating conditions.

Lights and Electrical System

The lights on a Construction Trailer Specialists, Inc. trailer meet or exceed federal regulations in effect at the time of manufacture.

For optimum performance and long life of the wiring and lights, follow the procedures below.

- ◆ Clean all reflectors and lights. See that all lights turn on and burn properly. Replace all burned out lights and broken reflectors with factory approved replacement parts.
- ◆ Inspect all wiring to ensure all connections are installed properly with no open or bare wires and the connections are sealed tight.
- ◆ Ensure there is clearance for turning and the cable wires are supportive and long enough if the vehicle were to jack-knife.

- ◆ When working on the trailer's electrical system, disconnect power to the unit.

Hydraulic Powered Cylinder

Tractor Wet Kit Minimum Requirements

- ◆ **Side Dump Trailer**
 - Pump: 20-25 GPM (*Gallons Per Minute*) recommended
 - Pressure: 2,000 PSI (*Pounds per Square Inch*)
 - Reservoir: 15 Gallons
- ◆ **End Dump Trailer**
 - Pump: 20-25 GPM (*Gallons Per Minute*) recommended
 - Pressure: 2,000 PSI (*Pounds per Square Inch*)
 - Reservoir: 45 Gallons
 - **NOTE:** On a 280" stroke length, a 60 gallon minimum reservoir is required.

Most end dump trailers use a single-acting "gravity down" cylinder while side dump trailers use a double-acting cylinder to operate the dump body. The control is located in the front of the trailer. Use the control to raise and lower the dump body. Use AW46 hydraulic fluid or equivalent for cylinder use. The hydraulic system is under extreme pressure. The pressure

WARNING

The hydraulic system is under extreme pressure. To reduce risk of injury, follow the precautions listed:

1. Always wear eye protection and protective clothing when working around hydraulic systems.
2. Fluid under pressure can pierce the skin and enter into the bloodstream causing death or severe injury.
3. A dump body must be supported to prevent movement while being inspected, serviced or repaired.

body or dump trailer. The hydraulic cylinder will not prevent the dump body or dump trailer from rollover or lateral tilt. The cylinder is strictly a lifting device and is not a structural member of the unit. The hydraulic cylinder mounted in the unit should be free to find its own trajectory line of extension, free of any lateral loading of the plungers. Misalignment of the top or bottom mountings, or mounting pins being too tight may cause scoring of the plungers, leaking, or improper sequencing which could cause the unit to tip over.

setting is 2,000 PSI. **DO NOT** allow the pressure to exceed 2,000 PSI or damage can be done to the trailer. Pressure can be in the hydraulic line(s) even when the power unit is not operating. **NEVER** disconnect a hydraulic line or fitting without first supporting the empty dump body and releasing the pressure from the line.

Hydraulic cylinders are **NOT** to be used as a stabilizer on a dump

NOTICE: AVISO

IF THE ABS INDICATOR LAMP COMES ON AND STAYS ON WHEN YOU APPLY THE BRAKES TO A MOVING VEHICLE, THE TRAILER ABS IS NOT WORKING PROPERLY. THE ABS MUST BE SERVICED AS SOON AS POSSIBLE UPON COMPLETION OF YOUR TRIP TO ENSURE FULL ANTI-LOCK BRAKING CAPABILITY.

SI LA LÁMPARA INDICADORA ABS SE ENCIENDE Y PERMANECE ENCENDIDA CUANDO USTED APLICA LOS FRENOS A UN VEHÍCULO EN MOVIMIENTO, EL REMOLQUE ABS NO FUNCIONA CORRECTAMENTE. EL ABS DEBE SER REVISADO EN SERVICIO TAN PRONTO COMO SEA POSIBLE AL TÉRMINO DE SU VIAJE PARA ASEGURAR SU CAPACIDAD COMPLETA DE FRENADO ANTIBLOQUEO.

BOTTOM DUMP TRAILER SERVICE INFORMATION

Air Filter Preventive Maintenance

The air filter filters out water from entering the lines and air cylinders. It needs to be checked and emptied on a regular basis. It is recommended the filter be checked during the daily inspection. Water in the lines can cause damage, especially if the semi-trailer is in sub-freezing conditions.



Prior to January 1, 2015

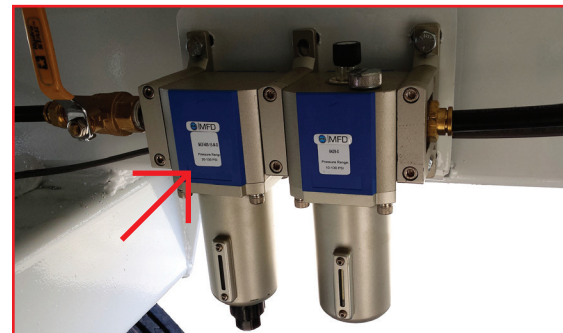

As of January 1, 2015

Oiler Filter Preventive Maintenance

The oiler is located next to the door operating valve. Oil is required to extend the life of the O-rings in the air cylinders. Check and fill the oil filter using air-tool oil (a multi-purpose lubricator or penetrating oil HMP050). The cycle of filling the oiler will depend upon the trailer's use. It is recommended to check the oil level during the daily inspection.



Prior to January 1, 2015



As of January 1, 2015

Bottom Dump Door Adjustment

The pitch control link adjustment is used to keep the doors closed. There should not be any movement in the pitch control link adjustment connection. If there is any play or movement, the jam nut will need to be loosened. Use a pipe wrench to turn the coupler nut and tighten the linkage. Verify there is no movement or play from hole to hole and re-tighten jam nut. Do not over tighten the linkage or the door will not close properly.

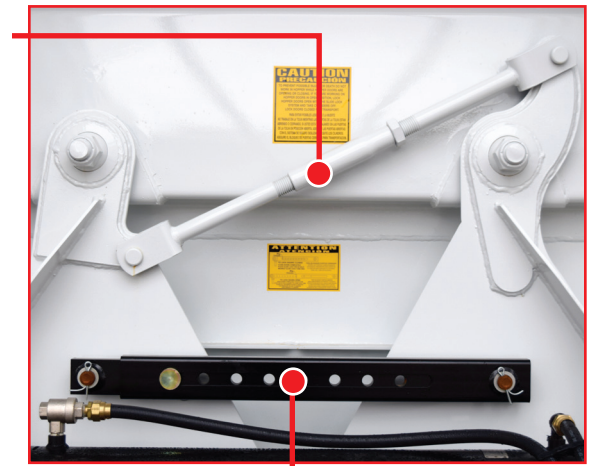

Servicing the Bottom Dump Door

The slide lock pin is designed to lock the doors shut when traveling and open during repairs. The locking pin should always be installed as shown below. Do not work on any door unless these locking pins are in the proper location and the air pressure has been released from door cylinders and the cylinders have been removed. Unpin only when the work is completed. Damage will occur to the trailer if both front and rear slide lock pins are not used. When hauling, the slide lock bar assembly **MUST** be locked in the closed position to avoid any accidental opening of the doors during transit.

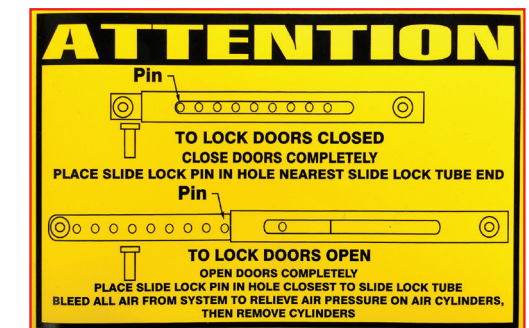

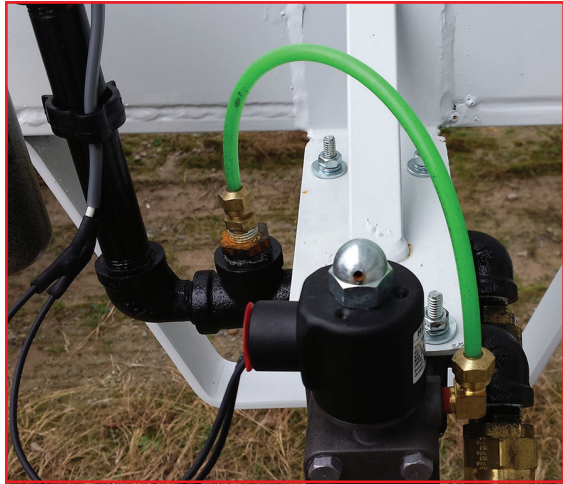

Repair of a Rexroth Solenoid

If your bottom dump trailer has a Rexroth valve and the doors have too much air coming out of the valve, and/or the doors take 15 to 20 seconds to open, then there is likely dirt in the plunger or acorn nut holes. Please follow the steps below to fix the problem.

1. Place slide lock pins in slide lock at proper location to prevent accidental opening.
2. Bleed air off from trailer. The air shut off is mounted next to the air filter "1/2" ball valve".
3. Loosen the acorn nut. Remove acorn nut from the valve assembly. Visually check to see if the holes are plugged.
4. If the holes are clean, then check the plunger.
5. To check the plunger on the solenoid, remove the protective

- cover (note the wires are attached to the cover).
6. Remove the magnetic washer from plunger.
7. While Construction Trailer Specialists, Inc. uses a special tool, vise grips or channel locks can be used to remove the plunger if not clamped onto the plunger too tight. Turn a 1/4 of a turn counter clockwise and the plunger can be unscrewed and lifted straight up. Be careful not to drop the stem, spring, or oil ring below the plunger.
8. Visually look through the plunger and see if it is plugged. You should be able to look through the hole. Blow air through the plunger until you can see through it.
9. Place the plunger back on the stem, spring, O-ring and hand tighten clockwise and then use vise grips for 1/8 to 1/4 of a turn.
10. Place the magnetic washer back onto the plunger and then attach the cover with the wires.
11. Hand tighten the acorn nut on the cover and then tighten clockwise about 1/8 to 1/4 turn.
12. Reposition slide lock pins and apply air to the system.

Test the doors. They should open or close in about 6 seconds.

WIRING DIAGRAMS

Bottom Dump Infinite Gate Wiring Diagrams

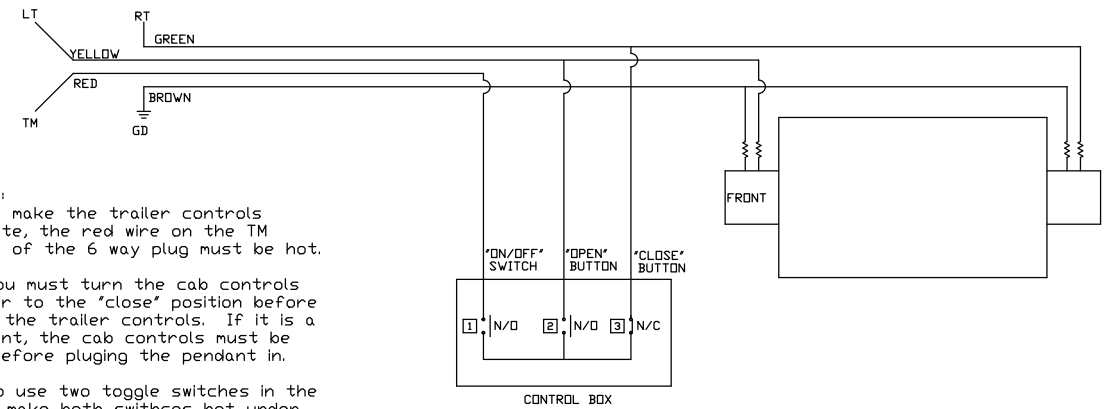

- Notes:
1. To make the trailer controls operate, the red wire on the TM prong of the 6 way plug must be hot.
 2. You must turn the cab controls off or to the 'close' position before using the trailer controls. If it is a pendant, the cab controls must be off before plugging the pendant in.
 3. To use two toggle switches in the dash, make both switches hot under the dash and connect the green wire to one and the yellow wire to the other. To operate the gates, turn one toggle switch on and the doors are in the neutral position. Turn both toggle switches on and the doors will start opening. Turn one toggle switch off and the doors will stop. Turn both toggle switches off and the doors will close.
 4. For trailers without trailer control box, the red wire is not used.

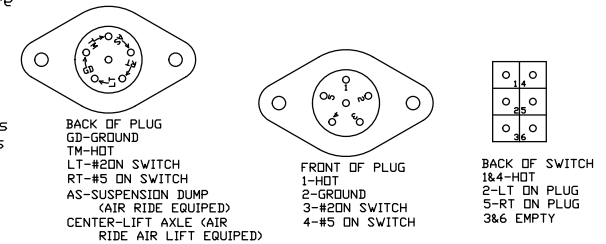

This scenario is for an On-On-On three way switch. To make it work with any other switch, you must have a hot wire to the back of the trailer. In one position of the switch, make the yellow wire hot, and in the next position of the switch, make the yellow and green wires hot at the same time.

6-Pin Plug

Wiring for Bottom Dump Door Control, Half Round High Lift Tailgate Control, & Side Dump HYD Dump Valve

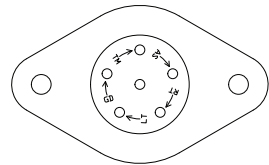

Back of Plug
 GD-Ground
 TM-Door Control
 TM-Hyd Dump Valve
 LT-Airride/Airlift Control
 RT-Airride Dump

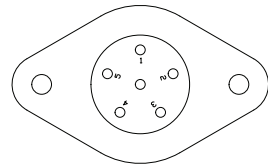

Front of Plug
 2-Ground
 1-Door Control or Hyd Dump
 3-Airride / Airlift Control
 4-Airride Dump

7-Pin Plug

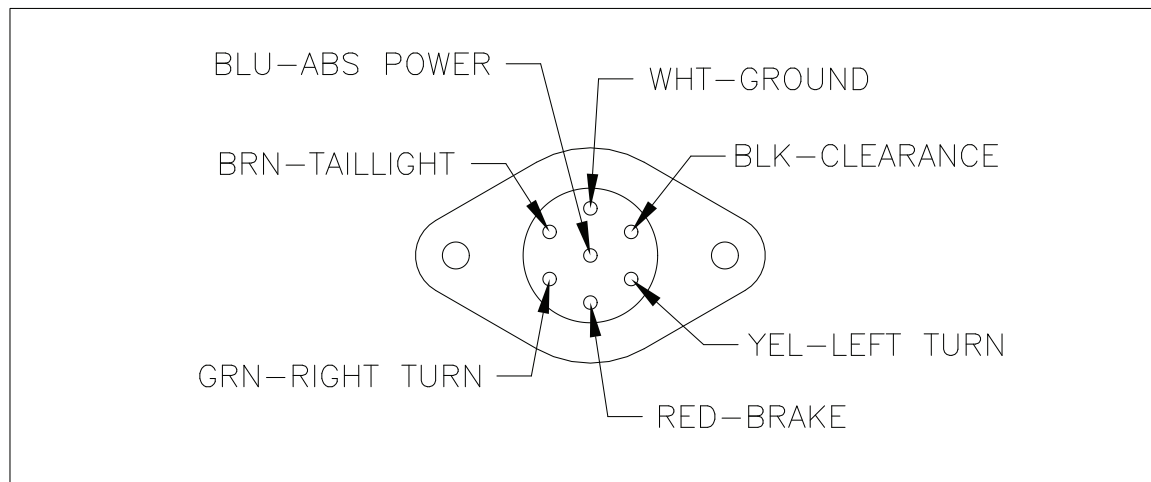

SIDE DUMP PLUG WIRING

TWO PIN TARP RECEPTACLE, VIEWED FROM FRONT OF TRAILER

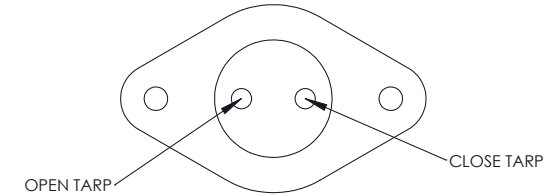

FOUR PIN CONTROL RECEPTACLE, VIEWED FROM FRONT OF TRAILER

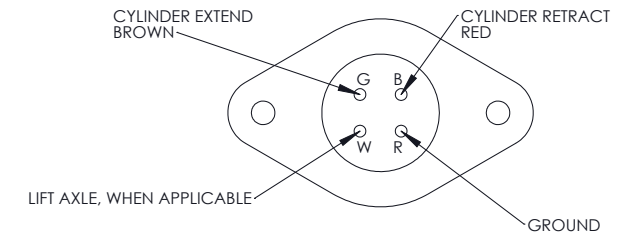

A 6 PIN CONTROL RECEPTACLE IS USED WHEN THE TRAILER IS EQUIPPED TO PULL A PUP TRAILER, VIEWED FROM FRONT OF TRAILER

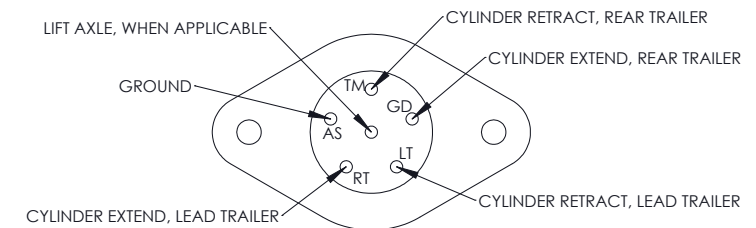

WARNING LABELS

If you need to re-order a label, please contact the Parts and Warranty Department by email at parts@trailerbuilders.com or by phone at 888-669-0003.



Attention: Please Read
LBL-001

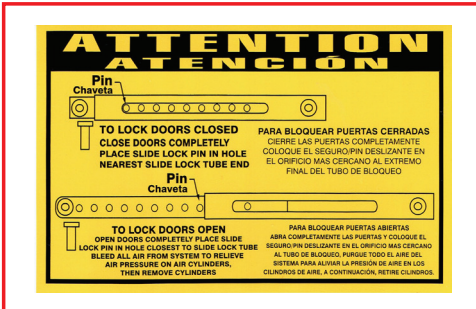

Attention: Slide Locks
LBL-002



Caution: Air Brake Additive
LBL-012



Notice: ABS Warning Light
LBL-013



Caution: Prevent Injury Hopper
LBL-003



Warning: Torque Wheel
LBL-009

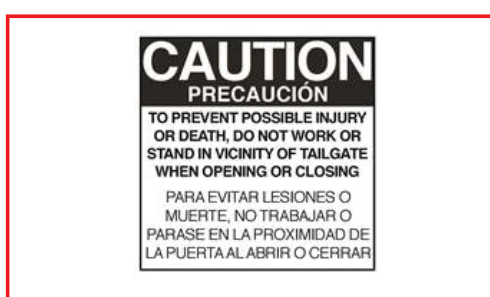

Caution: Stand Clear of Door
LBL-015



Warning: King Pin
LBL-014



Warning: Match Wheels
LBL-010



Danger: Brake Chambers
LBL-011

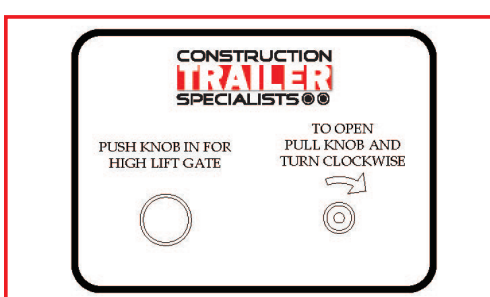

Double Hinge High Lift Gate
LBL-016



DOT Tags
TAG-001

WARNING LABELS (cont.) *Bottom Dump Trailer shown as reference only

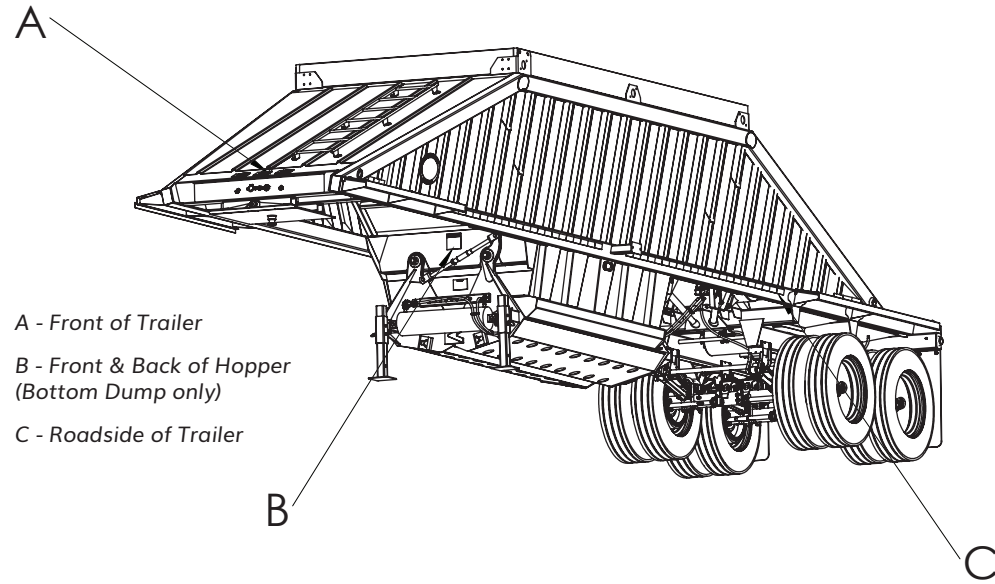

Guidelines for Conspicuity Tape: <https://www.fmcsa.dot.gov/regulations/title49/section/393.26>

	Grain Trailer	Bottom Dump	Elliptical	Half Round	Side Dump	LW End Dump
LBL-001		A	A	A	A	A
LBL-002		B				
LBL-003		B				
LBL-009	A	A	A	A	A	A
LBL-010	A	A	A	A	A	A
LBL-011	A	A	A	A	A	A
LBL-012	A	A	A	A	A	A
LBL-013	C	C	C	C	C	C
LBL-014	A	A	A	A	A	A
LBL-015		C	C	C	C	C
LBL-016				C		

WARRANTY INFORMATION

⚠ WARNING

- The warranty is void for any damage caused by misuse, abuse, neglect or acts of nature.
- The warranty does not cover any defects or costs caused by:
- Misuse and subsequent damage. Misuse is defined by, but not limited to, the cases described below.**
- Modification, alteration, repair or service of this product by anyone other than approved repair shops by Construction Trailer Specialists, Inc.;
 - Physical abuse to, overload of, or misuse of, the product or operation thereof in a manner contrary to the instructions accompanying the product;
 - Any use of the product other than that for which it was designed;
 - Failure to comply with care and maintenance instructions accompanying the product.

Construction Trailer Specialists, Inc. prides itself on manufacturing the best quality trailers on the market. However, should you encounter a problem, we back our trailers with the best warranty in the industry.

Construction Trailer Specialists, Inc. is known for providing exceptional customer service. We focus on taking action quickly so you

can get your trailer back on the road. Your calls are important to us. We guarantee your call will be answered by a human, not a recording, and your problem addressed immediately.

If you have any questions about the condition of your trailer, or wish to share any concerns, call your local dealer or call us at 888-669-0003.

Construction Trailer Specialists, Inc. • 2535 Rose Parkway • Sikeston, MO 63801
Toll Free: 888-669-0003 • Office: 573-481-0941 • Fax: 573-481-0953
www.constructiontrailerspecialists.com

CONSTRUCTION
TRAILER
SPECIALISTS ©©